

ME 419

POWER PLANT ENGINEERING

(Lecture 5: Circulating Water System)

Circulating-Water System

- ❑ The **circulating-water system** in power plants, which is responsible for rejecting excess heat to the environment in an efficient and environmentally compliant manner.
- ❑ Its performance significantly impacts the overall efficiency of the power plant.
- ❑ A condenser operating at the lowest possible temperature helps maximize turbine work and cycle efficiency while minimizing heat rejection, which reduces the need for cooling water.
- ❑ The heat rejected by this system is significantly larger than the useful work done by the steam cycle.

Circulating-Water System

□ For most power plants, both new and old, the heat rejected is typically 1.5 to 3 times the useful work output.

$$\dot{Q}_R = \left(\frac{1}{\eta} - 1 \right) \dot{W}$$

System Classification

1. Open-Loop Systems (Once-Through Systems)
2. Closed-Loop Systems
3. Combination Systems

Open-Loop Systems (Once-Through Systems)

Water is taken from a natural source (lake, river, or ocean), used to cool the condenser, and then returned to the source. Heat is rejected to the environment through various discharge methods.

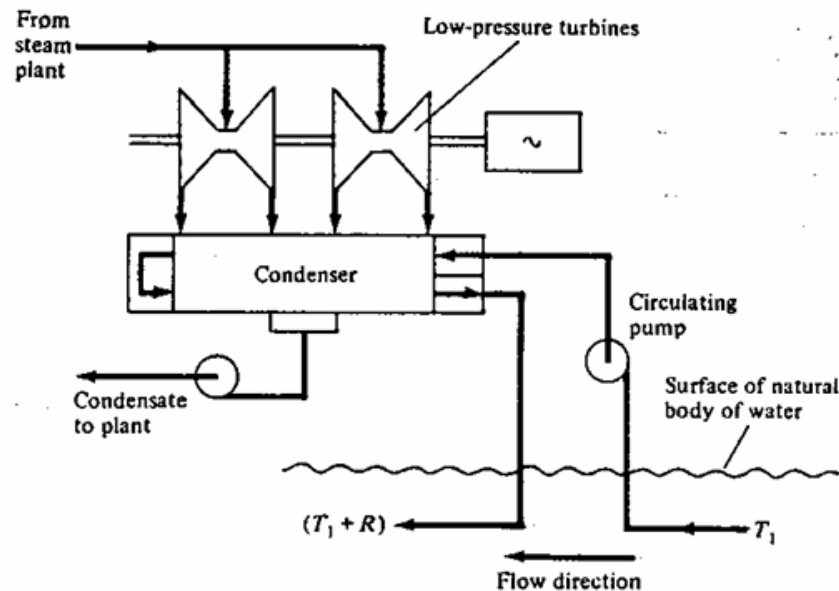

Figure 7-1 Schematic of a once-through circulating-water system.

Open-Loop Systems (Once-Through Systems)

Discharge Methods

1. **Surface Discharge**

Water is released in a thin layer on the surface of the water body. Cooling is achieved by:

Evaporation to the atmosphere.

Mixing with cooler water below.

2. **Submerged Discharge**

Heated water is released as a **buoyant jet** below the surface.

Heat dissipation occurs via:

Mixing with cooler water.

Evaporation from the mixture.

3. **Diffuser Discharge**

Water is released through multiple **nozzles** on a submerged pipe.

Promotes rapid mixing via jets (e.g., pointing upstream).

Heat is rejected by **evaporation**.

Closed Loop Circulating-Water System

- ❑ Water is circulated from the condenser through a **cooling device** and returned to the condenser.
- ❑ **Reservoirs** are often used between the cooling device and condenser.

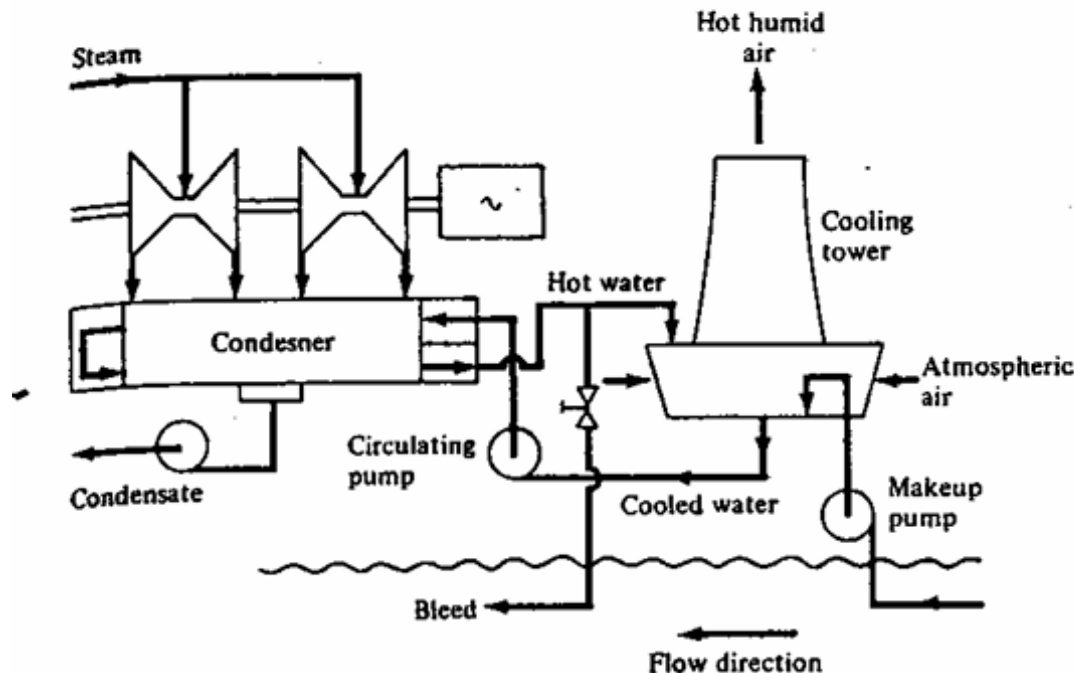

Figure 7-2 Schematic of a wet-cooling tower operating in the closed mode.

Closed Loop Circulating-Water System

□ Makeup Water:

- Sourced from nearby natural water bodies to:
 - Replace water lost via evaporation.
 - Handle blowdown discharge.

□ Types of Cooling Devices

1. Cooling Towers

Types:

Wet: Common and efficient.

Dry : Least efficient but requires no makeup water.

Ideal for deserts or where natural water usage is restricted.

Wet-Dry Combination:

Closed Loop Circulating-Water System

- ❑ Classified as **natural draft** or **mechanical draft**.
- ❑ In closed-loop operation, referred to as "closed mode"

2. Spray Ponds

Fine sprays of water cooled by **evaporation** through wind action.

3. Spray Canals

Similar to spray ponds but spray water as **larger droplets** to:

Reduce drift loss (water carried by wind).

Slightly lower cooling efficiency due to reduced mass transfer rates.

Closed Loop Circulating-Water System

4. Cooling lakes are areas in which the water is cooled naturally by evaporation and radiation. They are the least efficient of the three artificial bodies of water and therefore require the greatest acreage, but also the least mechanical equipment.

❑ **Combination systems** Combination systems combine once-through systems with a cooling device, usually a cooling tower, that cools the water before returning it to the natural body of water.

Cooling Tower operating in a open mode

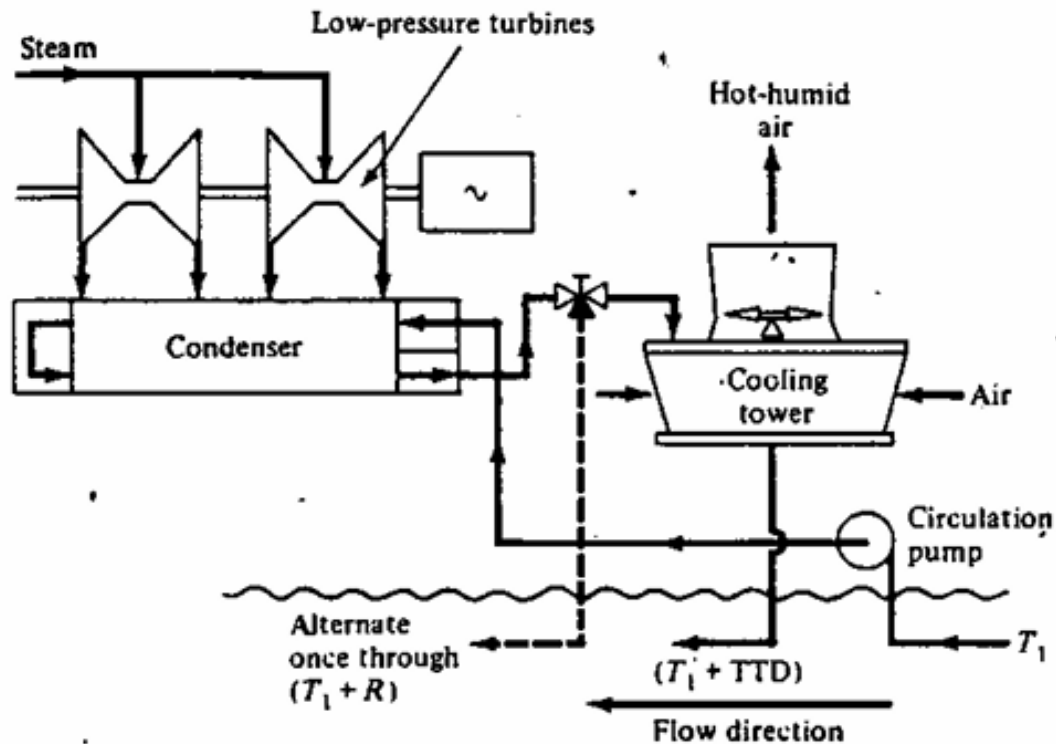

Figure 7-3 A wet-cooling tower operating in the open mode. An alternate once-through system is shown by the dashed line.

Cooling Tower Operating in helper mode

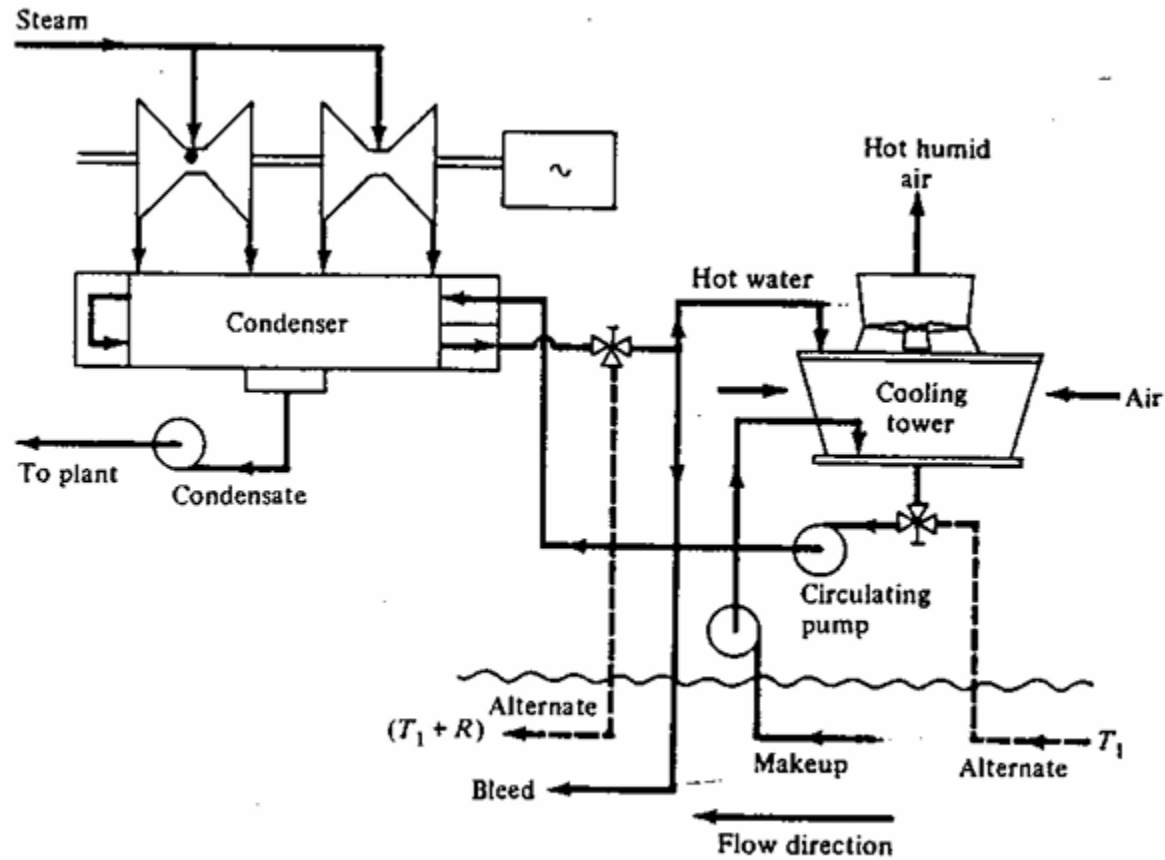

Figure 7-4 A wet-cooling tower operating in the helper mode.

Components of Circulating water System

1. An intake structure from a natural body of water in an open system or from cooling towers, spray ponds, etc. in a closed or helper mode
2. A circulating-water pumping station
3. Circulating-water conduits
4. Flow gates
5. Vacuum breaking system
6. Cold and warm water channels

Components of Circulating water System

The intake system for a circulating water system begins with a **skimmer wall** to draw cooler bottom water. The **intake structure**, typically made of reinforced concrete, is located at the end of the intake channel and contains equipment for debris removal.



Bar Racks:

- Mounted across each inlet bay with a 15° incline from vertical.
- Intercept large debris as water flows through.
- Debris is cleared using a **traversing trash rake**:
- The rake's basket has teeth to clean the rack.
- It collects debris as it moves upwards and dumps it into a trash cart for disposal.



Components of Circulating water System

2. Traveling Screens:

- ❑ Protect circulating-water pumps by filtering finer debris.
- ❑ Made of screen panels with 3/8-inch² openings, forming a loop across drive sprockets.
- ❑ Debris accumulates on stationary screens until pressure triggers automatic rotation for cleaning by a spray system.
- ❑ Debris is collected in trays, and manual control from the control room is available.
- ❑ Typically, there are six traveling screens per pump.

These components work together to ensure debris-free water supply to the system.

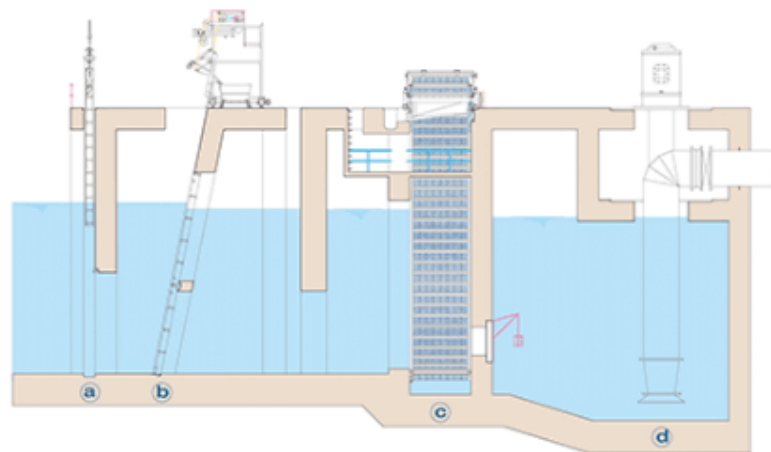

Components of Circulating water System

□ Circulating-Water Pumps:

- Large pumps operate in **parallel**; typically **three pumps per unit**.
- In **nuclear power plants**, one pump is sufficient to dissipate reactor shutdown decay heat.
- Emergency operation powered by **standby diesel generators**.

□ Pump Discharge:

- Equipped with **motor-operated butterfly valves** interlocked with pump motors to prevent surges.
- Combined water flow moves through a tunnel to the **condenser inlet conduit**.

Components of Circulating water System

□ Condenser Inlet:

- Conduit diameter: **6.5 ft (2 m)**.
- **Motor-operated butterfly valve** in a vertical section directs flow to the **divided inlet water box** of the condenser.

▪ Condenser Discharge:

- Similar butterfly valve arrangement for throttling or flow equalization.
- Ensures testing or balanced flow in case of multiple condensers.
- Water exits the condenser via a **discharge tunnel** into A **warm-water channel** leading to the **cooling tower**.
- Alternatively, water returns to the **pump reservoir** using **diffuser pipes Corrugated, perforated galvanized steel pipes** Laid across the reservoir bottom for **thermal mixing**.

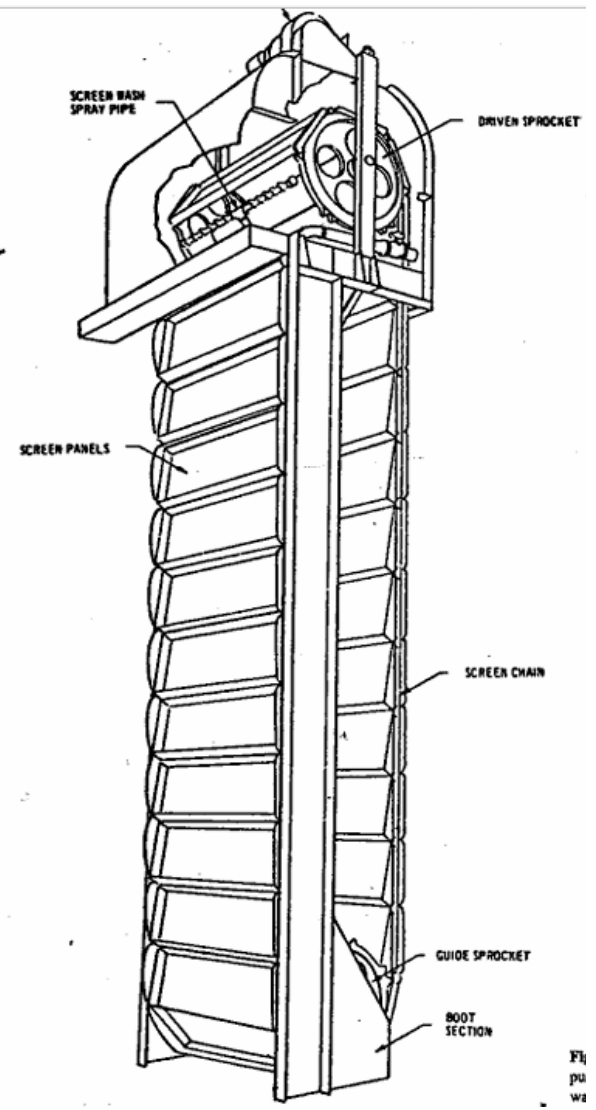
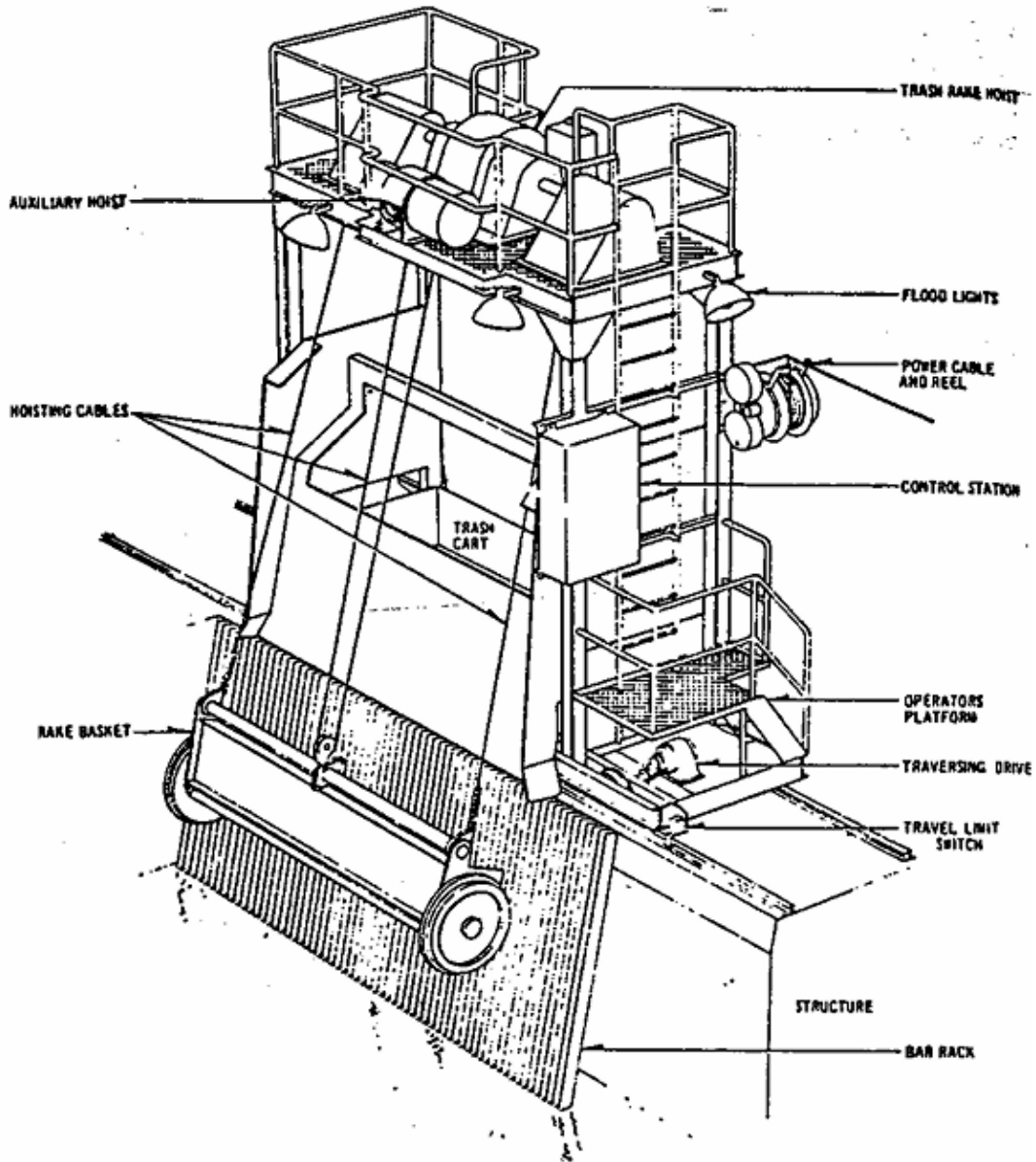
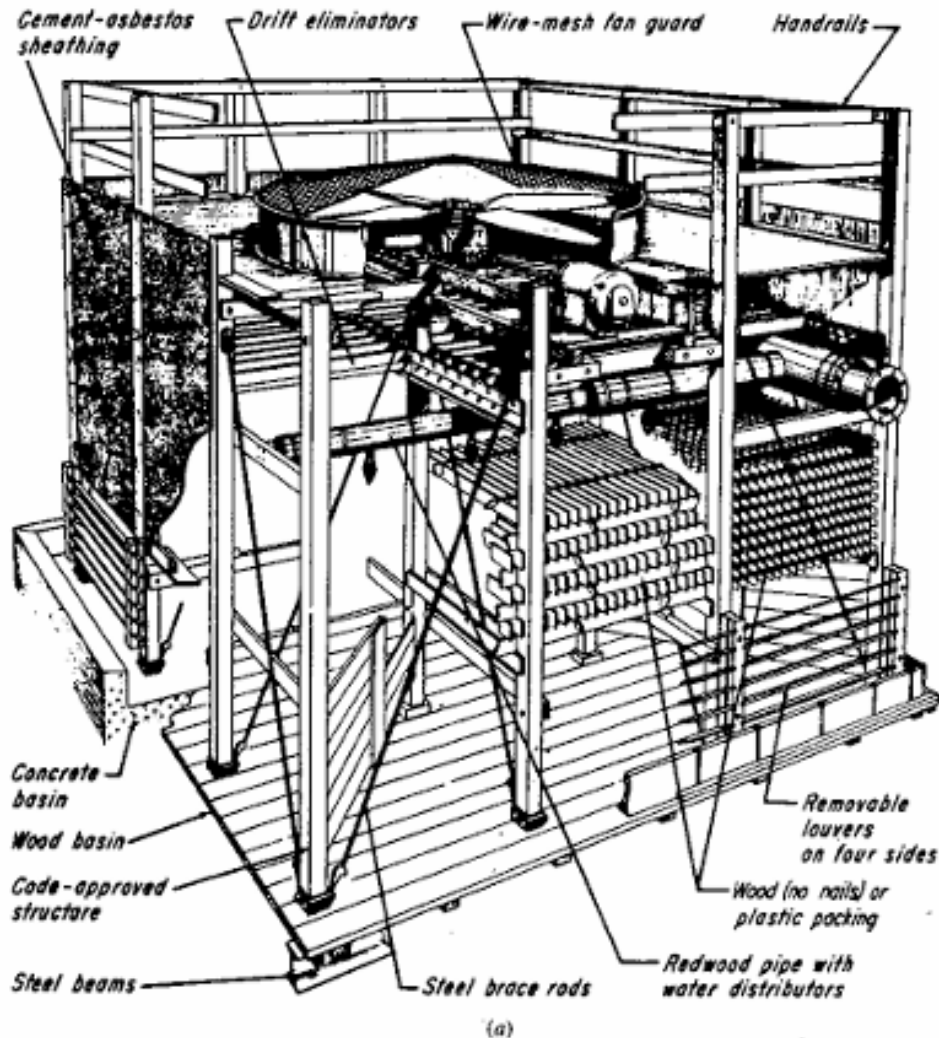

Figure 7-5 A typical intake system bar rack and traversing trash rake.

Components of Circulating water System

- ❑ In **closed or helper modes**, warm water from the condenser is pumped to **cooling towers**. Each cooling tower has a **dedicated pumping station** with **Two pumps per station**, located in separate reinforced structures.
- ❑ The discharge from the cooling towers flow into a number of common open cold-water channels **Over a weir** to balance water levels between cooling towers and the reservoir.
- ❑ **Vacuum Systems**: Installed at high points in tunnels (e.g., **warm-water channels**) to manage **syphon effects**. Vacuum maintained by a **vacuum priming system** under normal conditions.

Wet Cooling Tower



Wet-cooling towers are classified as:

- (1) mechanical-draft
- (2) Natural draft
 - (a) Counter flow
 - (b) Cross flow

Figure 7-7 The four types of wet-cooling towers: (a) mechanical-draft counterflow, (b) mechanical-draft cross-flow, (c) natural-draft counterflow, (d) natural-draft cross-flow [51,52]. (Not drawn to same scale.) (Continued on next two pages.)

Wet Cooling Tower

thoroughly addressed in the ME 307 course.

Dry Cooling Tower

- ❑ Circulating water passes through **finned tubes**, with heat rejected as **sensible heat** to cooling air.
- ❑ Can be either **mechanical-draft** or **natural-draft**.
- ❑ **Advantages:**
 - Allows plant siting **away from large water sources**.
 - Reduces costs:
 - **Fuel transportation** by siting near fuel sources.
 - **Power transmission** by siting near load centers.
 - **Lower maintenance costs** compared to wet towers (no chemical additives or frequent cleaning needed).
 - Avoids **thermal pollution** and issues like **fogging** or **icing**.
- ❑ **Disadvantages:**
 - Less efficient than wet cooling, leading to:
 - **Higher turbine back pressure**.
 - **Lower plant cycle efficiency**.
 - Increased heat rejection, especially in **high air temperatures**.
- ❑ **Applications:**
 - Widely used in Europe and gaining traction in the U.S. due to dwindling water supplies and stricter environmental regulations.
 - Common in **industrial-process cooling**, **air conditioning**, and **atmospheric air-cooled heat exchangers**.

Dry Cooling Tower

Types:

Direct Dry-Cooling Towers.

Indirect Dry-Cooling Towers.

Dry-cooling towers are designed for **closed-mode operation**, making them a sustainable choice for modern power plants.

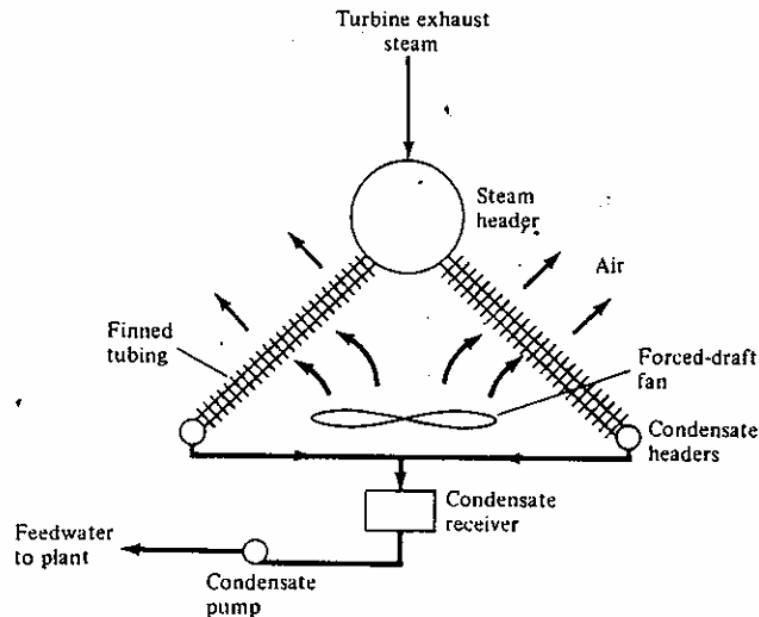

Figure 7-16 Schematic cross section of a direct dry-cooling tower.

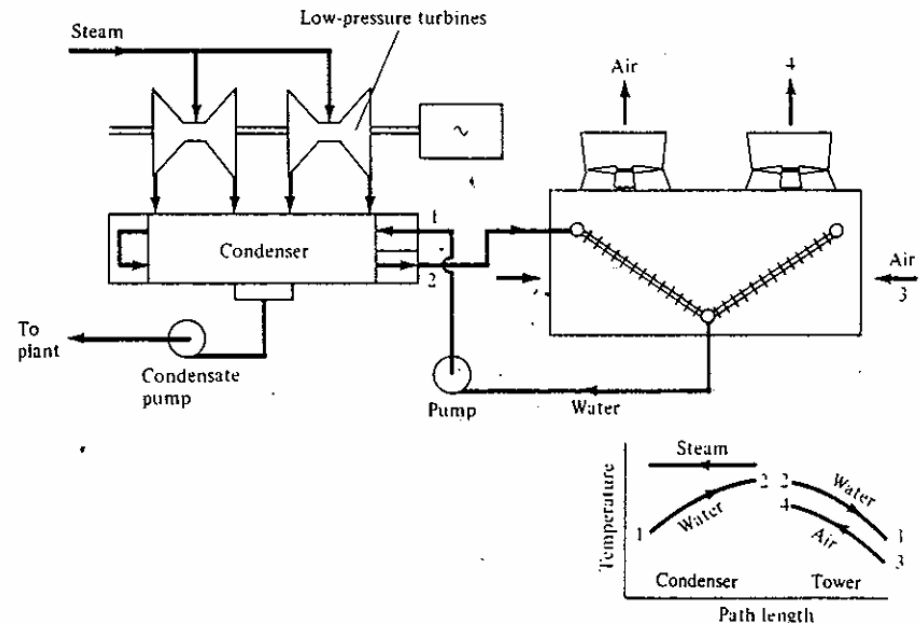

Figure 7-17 Schematic of an indirect dry-cooling tower with a conventional surface condenser.

Dry Cooling Tower

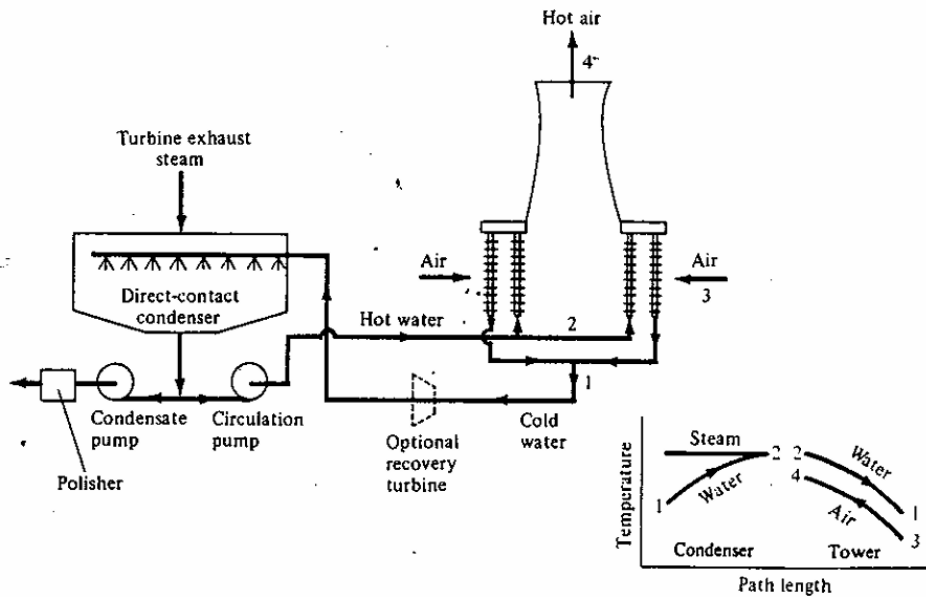

Figure 7-18 Schematic of an indirect dry-cooling tower with an open-type condenser.

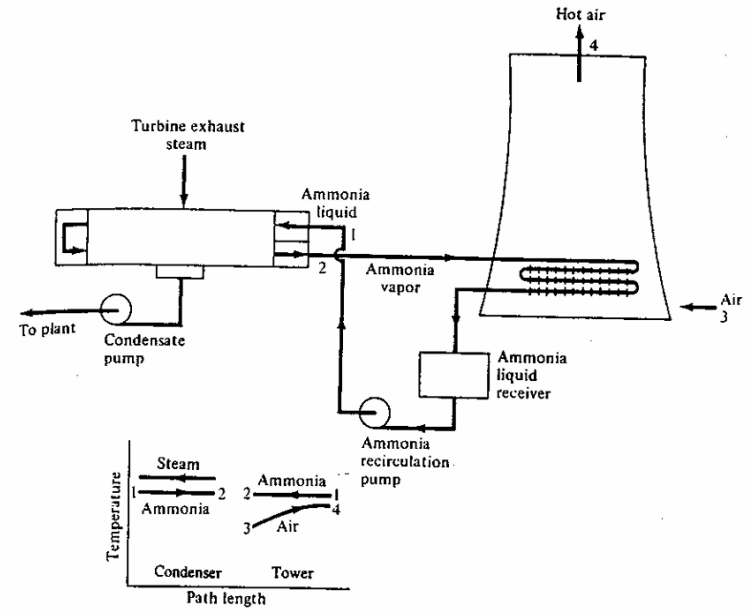

Figure 7-19 Schematic of an indirect dry-cooling tower with a surface condenser and a two-phase recirculating coolant (ammonia).

Dry Cooling Tower and Plant Efficiency

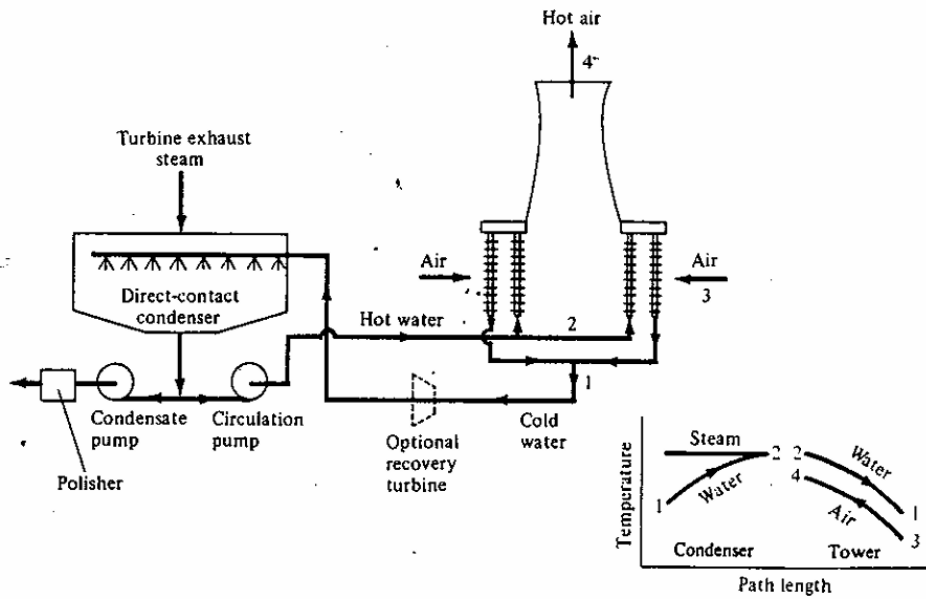

Figure 7-18 Schematic of an indirect dry-cooling tower with an open-type condenser.

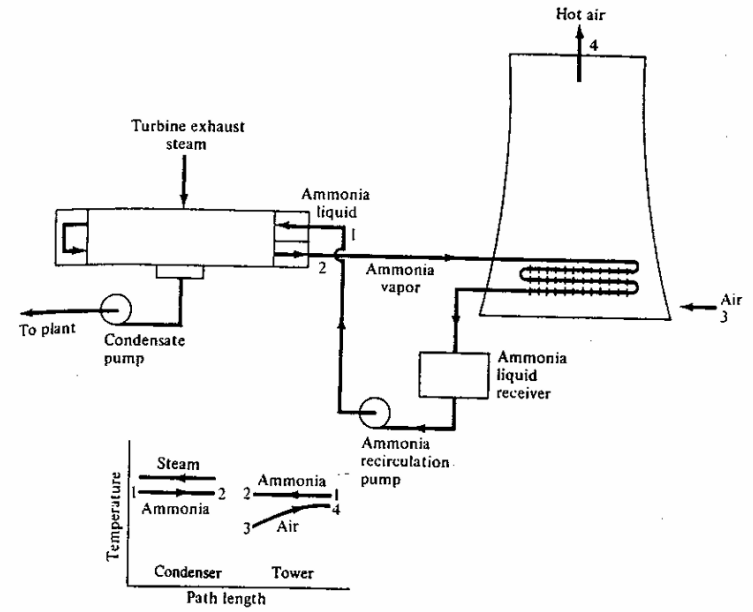

Figure 7-19 Schematic of an indirect dry-cooling tower with a surface condenser and a two-phase recirculating coolant (ammonia).

Dry Cooling Tower and Plant Efficiency

❑ Initial Temperature Difference (ITD):

ITD is the difference between the temperature of the hot water entering the tower and the **outside air temperature** (dry-bulb).

❑ The most economical ITD range is **50 to 60°F**.

❑ Heat Dissipation and Load:

Heat dissipation in dry-cooling towers is proportional to the **size of the cooling surface** and the **ITD**.

❑ **Increased load** leads to higher ITD, which raises the temperature of circulating water and increases **turbine back pressure**.

Dry Cooling Tower and Plant Efficiency

□ Impact of Outside Air Temperature:

- As outside air temperature increases, the **condensing temperature** and **pressure** also rise.
- With air at **90°F**, condensing temperatures can reach **156°F**, and pressures can rise to **4.31 psia (0.3 bar)**.

□ Comparison with Wet Towers:

- Dry-cooling towers are less efficient than wet towers because they rely on air cooling, which is less effective than evaporative cooling.
- Wet towers can maintain lower condensing pressures and temperatures, resulting in **lower turbine back pressure** and improved efficiency.

Dry Cooling Tower and Plant Efficiency

- **Dry-cooling towers** at **90°F** air could result in turbine back pressures between **4.31 and 4.74 psia**, whereas wet towers under similar conditions would have much lower pressures (**1.89 psia**).

□ **Effect of High Ambient Temperatures:**

- During hot weather, **condensing pressures** in dry-cooling towers can increase significantly, reducing turbine work and efficiency, leading to a larger cooling tower requirement.
- **Condensing pressures** may reach **6-7 psia** during extremely high temperatures, significantly impacting turbine efficiency.

Dry Cooling Tower and Plant Efficiency

□ Turbine Work Loss:

- Dry-cooling towers result in turbine work losses of around **6.5%** with air at **90°F**, compared to only **0.4%** for wet towers under similar conditions.

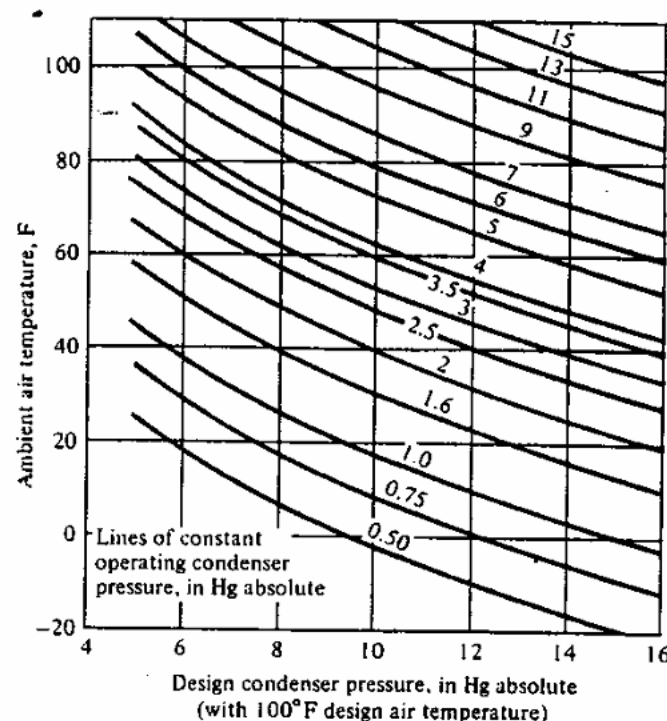

Cooling Lakes

Cooling lakes, also known as cooling ponds, are one of the oldest and simplest heat-rejection systems. They work by discharging hot circulating water from a power plant's condenser into a large body of water, which then cools naturally. The cooled water is returned to the circulating water system. The cooling process occurs through:

- i. **Evaporation:** Some heat is dissipated through evaporation from the lake surface.
- ii. **Thermal radiation:** Heat radiates to the sky, especially during clear nights.
- iii. **Convection:** Heat is transferred from the lake surface to the air.

Cooling Lakes

- i. **Cooling Effectiveness:** Cooling is slow and less efficient than mechanical systems, requiring large areas of land. To improve cooling, water can be circulated around baffle dikes or barriers.

□ Advantages

- i. **Simplicity and Low Maintenance:** Cooling lakes are simple to construct and maintain, with minimal mechanical equipment needed, mostly just pumps for water circulation.
- ii. **Low Power Requirements:** They don't require complex systems, just circulating pumps.
- iii. **Aesthetic Appeal:** The appearance of cooling lakes is less intrusive than cooling towers, and they can even be converted into recreational areas.

Cooling Lakes

i. **Extended Operation:** Cooling lakes can operate for long periods without needing makeup water.

❑ Disadvantages

i. **Low Cooling Efficiency:** The cooling process is slower, and very large land areas are required.

ii. **Large Acreage:** Cooling lakes require substantial space, which limits their feasibility.

iii. **Limited Flexibility:** The shape of the lake is relatively fixed, and cooling effectiveness depends heavily on the size of the lake.

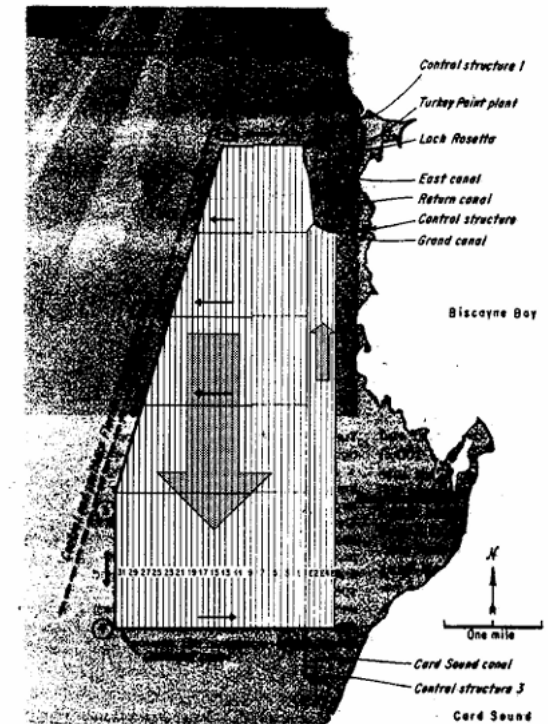

Problem-1

Warm water at $45\text{ }^{\circ}\text{C}$ enters a cooling tower at the rate of 6 kg/s . An ID fan draws $10\text{ m}^3/\text{s}$ of air through the tower and absorbs 4.90 kW . The air entering the tower is at $20\text{ }^{\circ}\text{C}$ dbt and 60% relative humidity. The air leaving the tower is assumed to be saturated and its temperature is $26\text{ }^{\circ}\text{C}$. Calculate the final temperature of the water and the amount of makeup water required per second. Assume that the pressure remains constant throughout the tower at 1.013 bar .